

SODIUM EDDY DIFFUSIVITY OF HEAT MEASUREMENTS IN A CIRCULAR DUCT

N. SHERIFF and D. J. O'KANE

UKAEA, Risley Nuclear Power Development Laboratories,
Risley, Warrington, Cheshire, U.K.

(Received 21 March 1979 and in revised form 30 June 1980)

Abstract—To determine the thermal conditions for certain LMFBR components it is often more convenient and economic to use simulant fluids. Important in translating such measurements to sodium temperatures are any differences in the turbulent Prandtl numbers. In this study the sodium eddy diffusivity of heat has been measured in the central region of a circular duct. The technique used, that of injecting heat along the duct centreline, is considered more suitable for such measurements than conventional methods. From the measurements of ε_H , values of Pr_T were evaluated over a Reynolds number range of 3×10^4 – 1.2×10^5 .

NOMENCLATURE

c ,	fluid specific heat;
f ,	Fanning friction factor;
Q ,	point heat source strength;
q ,	local radial heat flux;
R ,	distance from point heat source;
r ,	radial co-ordinate;
r_0 ,	duct radius;
T ,	fluid temperature;
u ,	axial velocity;
x ,	axial co-ordinate;
x^* ,	intercept on x -axis (Fig. 1);
x_w ,	see Fig. 1;
α ,	fluid thermal diffusivity;
ε ,	eddy diffusivity;
ν ,	fluid kinematic viscosity;
ρ ,	fluid density;
Pr_T ,	turbulent Prandtl number, $\varepsilon_M/\varepsilon_H$.

Subscripts

B ,	inlet;
H ,	heat;
M ,	momentum;
0 ,	centre-line;
T ,	total.

INTRODUCTION

THE EDDY diffusivity of heat in low Prandtl number fluids has been the source of much discussion ever since experimental liquid metal heat transfer measurements consistently fell below theoretical predictions. Applied to conventional sodium heat transfer conditions in LMFBR's the discrepancies are of academic interest since the temperature differences are small. This combined with the potential influence of other factors, notably that of natural convection at low Peclet numbers, has tended to reduce the need for any greater understanding of the turbulent heat transfer contribution. There are, however, some non-conventional heat transport features related to certain LMFBR components for which information on the

eddy diffusivity of heat is important. Two typical examples are:

1. The heat transfer between the sub-channels of a gridded fuel element cluster which alleviates temperature hot spots caused by the various tolerances.
2. The fluctuating temperature field produced in the plenum downstream of the core. The eddies producing the fluctuations interact thermally with the bulk flow to ameliorate the temperature fluctuations.

Both of the above examples can be studied extensively with simulant fluids, e.g. air or water, to obtain data in good geometrical representations of the reactor. The problem remains, however, of translating these measurements into sodium temperature conditions. An essential aid to this process are the differences between the turbulent Prandtl numbers (Pr_T) in the simulant fluid and sodium. The objective of the present experiment is to obtain Pr_T for sodium.

The applications noted above deal with conditions in the central region of a flow channel and not with wall effects. Consequently the experiment described purports to measure the sodium eddy diffusivity of heat in the central region ($r/r_0 < 0.5$) of a circular duct. Previously Sheriff and O'Kane [1] reported early data at a Reynolds number of 8×10^4 ; this paper presents the completion of the study and covers a Reynolds number range of 3×10^4 – 1.20×10^5 . Whilst the basic measurements made are of the eddy diffusivity of heat (ε_H), the data is finally expressed as Pr_T .

EXPERIMENTAL METHOD

In the experimental studies of the eddy diffusivity of heat in liquid metals the normal method used has been to measure the temperature distribution within the fluid of a circular duct with heat input at the wall. The eddy diffusivity of heat is then obtained from the equation defining ε_H :

$$\frac{q}{\rho \cdot c} = (\alpha + \varepsilon_H) \frac{dT}{dr}.$$

One experimental difficulty with this method is ensuring that the temperature profile is fully developed, particularly if values of ε_H in the central region are required. Simple slug flow calculations can indicate the duct lengths required to establish the temperature profile, and as Isakoff and Drew [2] demonstrated experimentally these lengths can be large. An additional complication for ε_H determinations in the central duct region, where the main interest lies in the present study, is that the measured temperature differences are small.

Because of the above disadvantages an alternative experimental method was sought. The one chosen stems from the empirical fact that velocity profiles can be satisfactorily correlated if a constant value of ε_M is used in the central region ($r/r_0 < 0.5$) of the duct. This has been shown by Hinze [3] in examining experimental data, and more recently by Quarumby and Anand [4] and Brinkworth and Smith [5]. Basically the method consists of supplying a continuous source of heat in the central region of a fully developed turbulent pipe flow and measuring the temperature distribution downstream of the source. This is an adaptation of the continuous source technique used to measure the eddy diffusivity mass, and for the present study has the major advantage that the temperature differences measured in the central duct region can be made sufficiently large to minimise experimental inaccuracies. The basic equation for the temperature field of a continuous point source of heat in a fluid with constant velocity U in an infinite field was first derived by Wilson [6] and is given by

$$\Delta T = T - T_B = \frac{Q}{4\pi\alpha_T R \rho c} \exp\left[-\frac{U(R-x)}{2\alpha_T}\right]. \quad (1)$$

With regard to the present work it is important to note that the assumptions made in the derivation of equation (1) are:

- A uniform thermal diffusivity
- A point source of heat
- A constant velocity
- No confining boundaries, i.e. an infinite field.

Where the experiment was thought to deviate significantly from these assumptions check tests were carried out; these are given in some detail by Sheriff and O'Kane [1]. Furthermore in that earlier paper it was established that the axial distribution of the peak temperatures gave the most satisfactory method for evaluating the total thermal diffusivity.

Along the axis of the tube $R = x$ and equation (1) reduces to

$$\Delta T_0 = \frac{Q}{4\pi\rho c\alpha_T x}. \quad (2)$$

Thus a plot of $Q/\Delta T_0$ against x should result in a straight line passing through the origin.

However it is found that a plot of $Q/\Delta T_0$ against x does not become linear until some way from the injection position $x = 0$ and that the straight line has

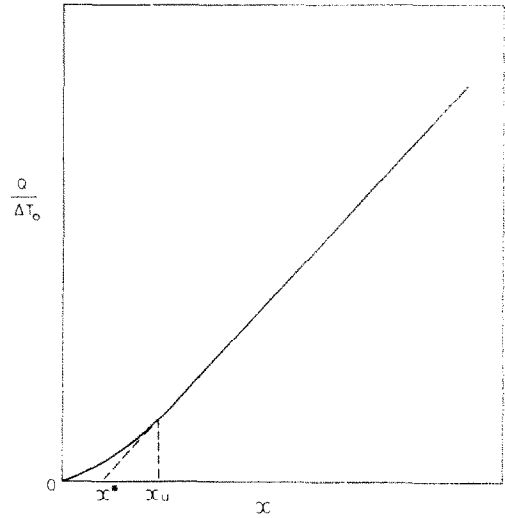

FIG. 1. Representation of axial temperature distribution.

an intercept x^* with the x -axis.

This is because the conditions for equation (2) are not strictly valid at short diffusion times represented by distances close to the injector. It has been shown [3] that for short diffusion times the diffusivity ε_H is a function of time and that only at long diffusion times will ε_H and thus α_T become constant.

Thus a plot of $Q/\Delta T_0$ against x does not become linear until $x = x_u$, where x_u is assessed from experimental results and the relevant equation for $x > x_u$ is

$$\Delta T_0 = \frac{Q}{4\pi\rho c\alpha_T(x-x^*)}. \quad (3)$$

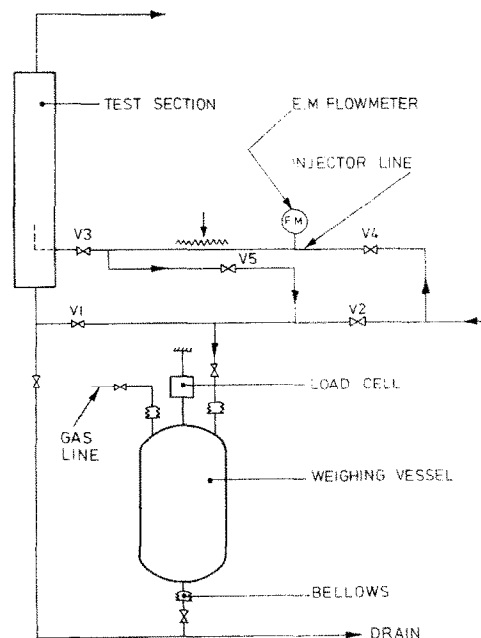

FIG. 2. Eddy diffusivity rig.

(A representation of x_w and x^* is shown in Fig. 1.)

From the slope of the graph of $Q/\Delta T_0$ against x the total thermal diffusivity (α_T) is obtained, and subsequently ε_H can be evaluated from $\varepsilon_H = \alpha_T - \alpha$.

DESCRIPTION OF RIG AND TEST SECTION

The eddy diffusivity rig forms part of a large sodium facility [7] in the Risley Nuclear Laboratories. The main facility contains the sodium pumps and purification equipment and provides a supply of sodium at 200–300°C to the eddy diffusivity rig.

A simplified flow diagram of the eddy diffusivity experiment is shown in Fig. 2. The majority of the flow from the main sodium facility passes into the test section directly but a small proportion is preheated to about 600°C before entering the test channel through the injector.

The test section, Fig. 3, is an 8.23 cm I.D. stainless steel pipe, 150 cm long into which the injector and traversing heads are installed. The test section is preceded by a 25 diameter flow straightening length.

The injector, Fig. 4, is of a double tube construction with the sodium flow in the inner tube. The interspace between the tubes is capable of being evacuated to minimise heat losses along the 25 cm length of the injector. An aerofoil shaped spider supports and centralises the injector in the test section so that the injector is concentric with the axis of the test section within a 0.125 mm dia tolerance zone along its length.

The traversing heads containing the traversing thermocouples are located at eight axial positions

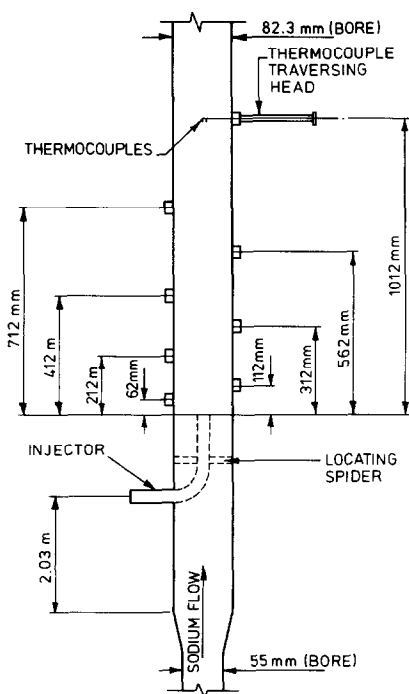

FIG. 3. Test section arrangement.

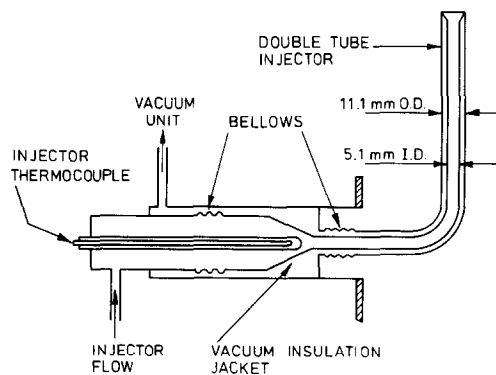

FIG. 4. Injector tube arrangement.

downstream from the injector outlet at distances from 6.2 to 101.2 cm as shown in Fig. 3. Traversing at three positions, 11.2, 21.2 and 41.2 cm was available in two directions at right angles to check the symmetry of the temperature profile.

Each traversing head contains two 0.5 mm mineral insulated stainless steel sheathed chromel–alumel thermocouples. The thermocouples pass down the bore of an 0.32 cm hypodermic tube which is held within the main 2.5 cm barrel of the traversing head by 3 convoluted bellows in series. The hypodermic probe carrying the thermocouples can either be fully retracted from the test section or traversed in 0.1 mm steps across a diameter of the test section.

Thermocouples were spot welded onto the outer surface of the test section circumferentially and along its length and also on the outer barrels of the traversing heads. The test section and traversing heads could thus be maintained at the nominal sodium inlet temperature by adjusting the variac supplies to the test section trace heating.

Upstream of the injector to measure the sodium inlet temperature to the main channel a platinum resistance sensor and an 0.5 mm chromel–alumel mineral insulated reference thermocouple are installed in pockets. The injector temperature is measured with a 1 mm dia platinum–platinum 13% rhodium thermocouple inserted into the inner tube of the injector as shown in Fig. 4.

INSTRUMENTATION

The traversing thermocouples are connected into chromel–alumel terminal blocks connected to the cold end of the hypodermic traversing strut. From these terminal blocks compensating leads are run to the reference junction. The reference junction which enclosed the switching system was an oil bath maintained at a nominal 50°C to within 0.01°C by a Tecam Tempunit.* The platinum–platinum Rhodium thermocouple did not have compensating cable and was brought directly to the reference junction. The thermo-

* Techne Cambridge Ltd, Duxford, Cambridge.

Table 1. Eddy diffusivities from axial distributions

Reynolds number	Sodium Prandtl number	Total diffusivity α_T ($10^{-6} \text{ m}^2/\text{s}$)	Eddy diffusivity ε_H ($10^{-6} \text{ m}^2/\text{s}$)	ε_H/α	Pr_i
3×10^4	7.2×10^{-3}	66.3 ± 3.8	0 ± 3.8	0 ± 0.06	r
4×10^4	7.2×10^{-3}	86.5 ± 3.4	19.5 ± 3.4	0.29 ± 0.5	1.96
6×10^4	7.2×10^{-3}	95.7 ± 2.5	28.6 ± 2.5	0.43 ± 0.04	1.85
8×10^4	7.2×10^{-3}	112 ± 3.8	44.8 ± 3.8	0.67 ± 0.06	1.54
1×10^5	7.1×10^{-3}	124 ± 5.0	57.1 ± 5.0	0.85 ± 0.08	1.45
1.2×10^5	7.1×10^{-3}	151 ± 2.9	74.1 ± 2.9	1.11 ± 0.05	1.35

couples were then routed to a Solartron* type LM 1402 digital voltmeter and Clairry† printer. The data transfer unit was connected such that the first five points read flowmeter outputs, sodium inlet temperature and injector temperature. The remaining fifteen points were then wired so that 15 readings of a selected traversing thermocouple were obtained thus ensuring a good time average of the fluctuating signals associated with the traversing thermocouples.

EXPERIMENTAL RESULTS

Using the optimum experimental conditions established by Sheriff and O'Kane [1] measurements of the total diffusivity were made in the Reynolds number range 3×10^4 – 1.2×10^5 . These values are tabulated in Table 1 where the results from the axial temperature profiles, see typically Fig. 5, have been used. The maximum temperature at each axial position was found from radial traverses (Fig. 6).

From the total diffusivities it is possible to evaluate the eddy diffusivity of heat and hence the ratio ε_H/α . The latter is shown in Fig. 7 as a function of Reynolds number.

DISCUSSION

The first reported data of measured eddy diffusivities of heat in sodium were by Borishanskii *et al.* [8] at a fluid temperature where $Pr = 7.5 \times 10^{-3}$. Using the conventional method with a heat flux at the wall they derived ε_H from temperature traverses; their values at the pipe centre line are shown in Fig. 7 for comparison with the curve representing the present measurements. The agreement is not good, but closer examination of the data used indicates that in the central pipe region ($0 < r/r_0 < 0.5$) the total temperature differences was only $\sim 1^\circ\text{C}$. Accurate measurement of such small temperature differences is difficult in sodium and this could be a contributory factor to the differences from the present measurements. A further qualification to be noted is that fully developed temperature profiles, particularly in the pipe central region, may not have been achieved in the short test section ($L/D \sim 32$). This latter point is given extra

foundation from the observations that the assessed overall heat transfer coefficients are greater than Martinelli's predictions.

The only other measurements made in sodium are those of Fuchs [19] at a $Pr \sim 7 \times 10^{-3}$. Here again the values of ε_H were obtained from temperature traverses in a pipe with a wall heat input, but in this case there is a much better agreement with the present data. The mean values between $r/r_0 = 0$ to 0.5 are shown in Fig. 7 together with the estimated uncertainty in the measurements. Noting the uncertainty in the present data (see Table 1) it is seen that the present results and those of Fuchs are in excellent agreement.

To evaluate the turbulent Prandtl number the magnitude of ε_M is required in addition to the measured ε_H . For the central region of the pipe the expression given by Hinze [3], $\varepsilon_M/\nu = 0.035\sqrt{(f/2)}$, is representative of most current measurements and has been used here. With this value Pr_T is shown in Fig. 8 as a function of the Reynolds number. Below $Re = 4 \times 10^4$ the value of Pr_T increases rapidly to infinity since $\varepsilon_H \rightarrow 0$ at $Re = 3 \times 10^4$. This is not a very important region for sodium heat transfer since the value of ε_H is less than 25% of the thermal diffusivity of sodium.

Although there is a distinct trend for Pr_T to decrease with increasing Reynolds number, within the limits of

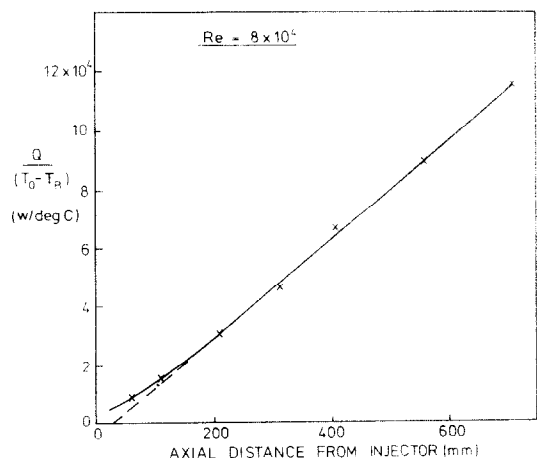

FIG. 5. Typical axial temperature distribution.

* Solartron Electrical Group Ltd, Farnborough, Hampshire.

† Clairry Ltd, Welling, Kent.

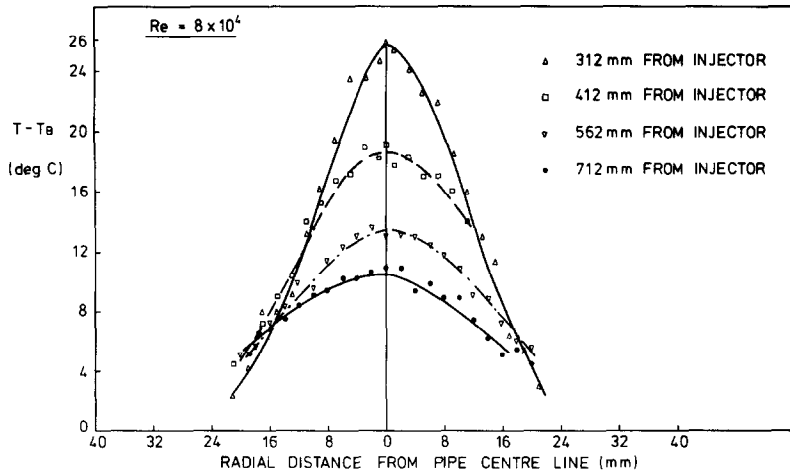

FIG. 6. Radial temperature distributions.

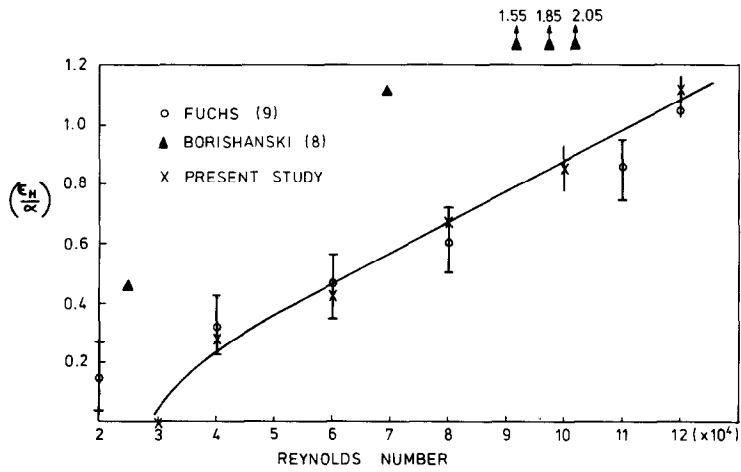

FIG. 7. Measured eddy diffusivities of heat.

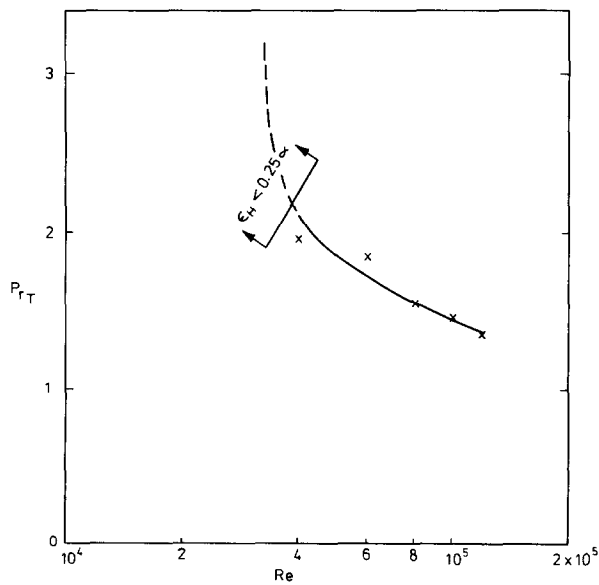

FIG. 8. Turbulent Prandtl number for sodium.

the present experiment it is always greater than unity. This is to be compared with values for air which are consistently less than unity, despite the variations reported which give a range from 0.8 to 1.0. Since air is often used as a simulant fluid to represent sodium thermal-hydraulic conditions away from the walls in scaled reactor models, these differences must be considered and corrections made. Even at high Reynolds numbers it is possible that this will be necessary if a high degree of accuracy is required. In practice it is preferable to determine the correction factors from experiments in both sodium and the simulant fluid with the same geometrical configuration. For example the present study was complementary to air measurements of the turbulent Schmidt number [10] for the evaluation of the necessary correction factor; a mass transfer rather than heat transfer experiment was used in a scaled air model of the reactor configuration. The general application of the present results must be approached tentatively since changes in configuration could affect the values of Pr_T .

CONCLUSIONS

The main conclusions are:

- (1) That the method of injecting hotter fluid on the duct centre-line has proved to be a most satisfactory way to measure ε_H in the central region.
- (2) The measured values of ε_H in sodium are in excellent agreement with the most recent measurements made by Fuchs.
- (3) The sodium Pr_T is, unlike conventional fluids, always greater than unity in the Reynolds number range studied.
- (4) Corrections factors will invariably be needed when

predicting sodium temperatures from measurements in simulant fluids.

Acknowledgements—The authors are indebted to the professional engineering advice given by Mr B. Mather at all stages of the project. This paper is published by permission of the Managing Director of the Northern Division of the United Kingdom Atomic Energy Authority.

REFERENCES

1. N. Sheriff and D. J. O'Kane, Sodium eddy diffusivity of heat measurements in a circular duct, *Progress in Heat and Mass Transfer*, Vol. 7, pp. 25–38. Pergamon Press, Oxford (1973).
2. S. E. Isakoff and T. B. Drew, Heat and momentum transfer in turbulent flow of mercury, in *Proc. General Discussion on Heat Transfer*, Inst. Mech. Engng and ASME, pp. 405–405 (1961).
3. J. O. Hinze, *Turbulence*. McGraw Hill, New York.
4. A. Quarmby and R. K. Anad, Axisymmetric turbulent mass transfer in a circular tube, *J. Fluid Mech.* **38**, 433–455 (1969).
5. B. J. Brinkworth and P. C. Smith, Velocity distribution in the core of turbulent pipe flow, *Chem. Engng Sci.* **24**, 787–791 (1968).
6. H. A. Wilson, On convection of heat, *Proc. Camb. Phil. Soc.* **12**, 406 (1904).
7. K. G. Eickhoff, J. Allen and C. Boorman, Engineering development for sodium systems, Proc of BNES Conference on Fast Breeder Reactors, London (1966).
8. V. M. Borishanski and T. B. Zablotkaya, High conductivity fluid flow turbulent heat transfer, *Atomn. Energ.* **22**, 2 (1967).
9. H. Fuchs, Heat transfer to flowing sodium, Thesis from Institut für Reaktorforschung Würenlingen Schweiz, EIR-Bericht Nr 241 (1973).
10. N. Sheriff and D. J. O'Kane, Eddy diffusivity of mass measurements for air in a circular duct, *Int. J. Heat Mass Transfer* **14**, 697–707 (1971).

MESURE DE LA DIFFUSIVITE TURBULENTE DE LA CHALEUR POUR DU SODIUM DANS UNE CONDUITE CIRCULAIRE

Résumé—Pour déterminer des conditions thermiques dans des éléments de réacteur à neutrons rapides, on utilise des fluides de simulation. Dans la transposition de telles mesures au cas du sodium on doit tenir compte des différences dans les nombres de Prandtl. Dans cette étude on a mesuré la diffusivité thermique turbulente dans la région centrale d'une conduite circulaire. La technique utilisée, d'injection de chaleur le long de l'axe du tube, est considérée comme mieux adaptée que les méthodes conventionnelles. Des mesures de ε_H , les valeurs de Pr_T sont tirées dans un domaine de nombre de Reynolds compris entre 3×10^4 et $1,2 \times 10^5$.

TURBULENTER SCHEINWÄRMELEITKOEFFIZIENT VON NATRIUM

Zusammenfassung — Um die thermischen Bedingungen für bestimmte Komponenten eines mit flüssigem Metall gekühlten Schnellen Brütters (LMFBR) festzulegen, ist es oft vorteilhafter und wirtschaftlicher, Vergleichsflüssigkeiten zu verwenden. Wichtig beim Übertragen solcher Messungen auf Natriumtemperaturen sind Unterschiede in den turbulenten Prandtl-Zahlen. In dieser Untersuchung wurde der turbulente Scheinwärmeleitkoeffizient von Natrium im Innern eines Kreisrohres gemessen. Die verwendete Methode, die Wärme entlang der Rohrmittellinie zuzuführen, ist für solche Messungen geeigneter als herkömmliche Methoden. Aus den Messungen von ε_H wurden über einen Reynolds-Zahlenbereich von $3 \cdot 10^4$ bis $1,2 \cdot 10^5$ Prandtl-Zahlen Pr_T berechnet.

**ВИХРЕВАЯ ТЕМПЕРАТУРОПРОВОДНОСТЬ НАТРИЯ ПРИ ИЗМЕРЕНИИ
ТЕПЛОВОГО ПОТОКА В КОЛЬЦЕВОМ КАНАЛЕ**

Аннотация — Для определения тепловых режимов контуров теплоносителя реакторов часто более удобно и экономично использовать модельные жидкости. Но при обобщении результатов таких измерений на случай натриевого теплоносителя необходимо учитывать несоответствие значений турбулентного числа Прандтля. В настоящей работе делается попытка непосредственного измерения вихревой теплопроводности натрия. Измерения проводились в центральной части кольцевого канала. Показано, что использованный в данном эксперименте метод аксиального подвода тепла при таких измерениях является более пригодным, чем обычно применяемые методы. По результатам измерений ϵ_H рассчитаны значения Pr_T в диапазоне чисел Рейнольдса от 3×10^4 до $1,2 \times 10^5$.